

EC-max 22 Ø22 mm, brushless, 25 Watt

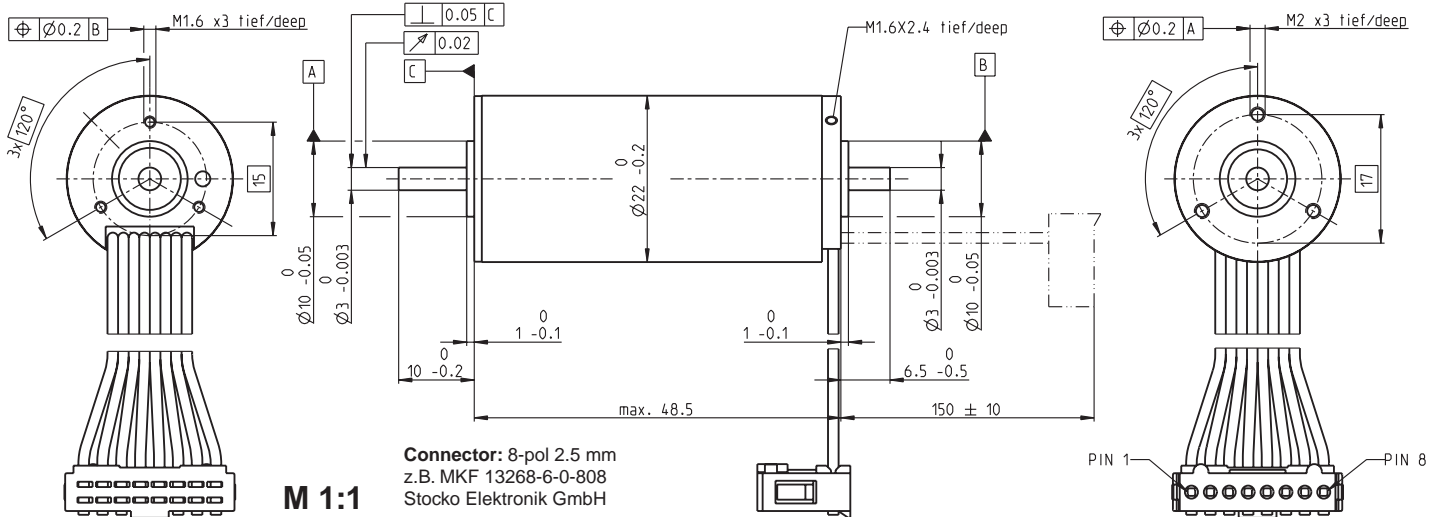

- Stock program
- Standard program
- Special program (on request)

Part Numbers

283856	283857	283858	283859	283860
--------	--------	--------	--------	--------

Motor Data

Values at nominal voltage		12	18	24	36	48
1 Nominal voltage	V	12	18	24	36	48
2 No load speed	rpm	12400	12900	12900	12200	12900
3 No load current	mA	226	161	121	73.5	60.4
4 Nominal speed	rpm	9800	10300	10400	9630	10500
5 Nominal torque (max. continuous torque)	mNm	23	21.8	22.7	22.5	23.2
6 Nominal current (max. continuous current)	A	2.71	1.8	1.4	0.872	0.716
7 Stall torque	mNm	114	112	121	111	127
8 Stall current	A	12.6	8.55	6.97	4	3.66
9 Max. efficiency	%	76	75	76	75	77
Characteristics						
10 Terminal resistance phase to phase	Ω	0.955	2.1	3.44	9.01	13.1
11 Terminal inductance phase to phase	mH	0.0498	0.103	0.182	0.462	0.729
12 Torque constant	mNm/A	9.1	13	17.4	27.7	34.8
13 Speed constant	rpm/V	1050	732	549	345	274
14 Speed/torque gradient	rpm/mNm	110	118	109	112	103
15 Mechanical time constant	ms	5.14	5.5	5.06	5.23	4.82
16 Rotor inertia	gcm ²	4.45	4.45	4.45	4.45	4.45

Specifications

Thermal data		
17 Thermal resistance housing-ambient		10.2 K/W
18 Thermal resistance winding-housing		1.02 K/W
19 Thermal time constant winding		1.99 s
20 Thermal time constant motor		628 s
21 Ambient temperature		-40...+100°C
22 Max. winding temperature		+155°C
Mechanical data (preloaded ball bearings)		
23 Max. speed		18000 rpm
24 Axial play at axial load < 4 N		0 mm
	> 4 N	0.14 mm
25 Radial play		preloaded
26 Max. axial load (dynamic)		3.5 N
27 Max. force for press fits (static)		60 N
(static, shaft supported)		1000 N
28 Max. radial load, 5 mm from flange		16 N

Other specifications

29 Number of pole pairs	1
30 Number of phases	3
31 Weight of motor	110 g

Values listed in the table are nominal.

Connection (Cable AWG 24)		
brown	Motor winding 1	Pin 1
red	Motor winding 2	Pin 2
orange	Motor winding 3	Pin 3
yellow	V _{Hall} 3...24 VDC	Pin 4
green	GND	Pin 5
blue	Hall sensor 1	Pin 6
violet	Hall sensor 2	Pin 7
grey	Hall sensor 3	Pin 8

Wiring diagram for Hall sensors see p. 33

Operating Range

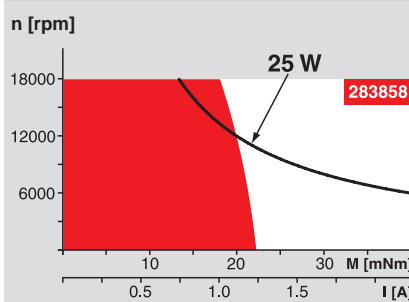

Comments

Continuous operation
In observation of above listed thermal resistance (lines 17 and 18) the maximum permissible winding temperature will be reached during continuous operation at 25°C ambient.
= Thermal limit.

Short term operation
The motor may be briefly overloaded (recurring).

— Assigned power rating

maxon Modular System

Planetary Gearhead
Ø22 mm
0.5 - 3.4 Nm
Seite 294/297

Planetary Gearhead
Ø32 mm
1.0 - 6.0 Nm
Page 308

Koaxdrive
Ø32 mm
1.0 - 4.5 Nm
Page 312

Spindle Drive
Ø32 mm
Page 334-336

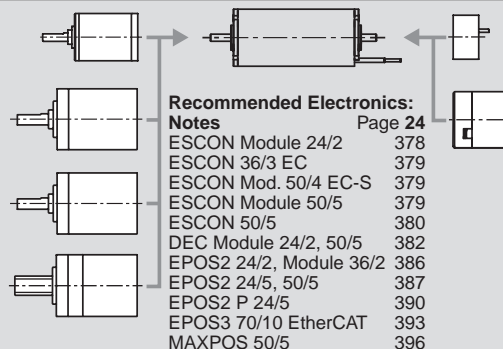

Recommended Electronics:

Notes	Page 24
ESCON Module 24/2	378
ESCON 36/3 EC	379
ESCON Mod. 50/4 EC-S	379
ESCON Module 50/5	379
ESCON 50/5	380
DEC Module 24/2, 50/5	382
EPOS2 24/2, Module 36/2	386
EPOS2 24/5, 50/5	387
EPOS2 P 24/5	390
EPOS3 70/10 EtherCAT	393
MAXPOS 50/5	396

Overview on page 20-25

Encoder MR
128/256/512 CPT,
2/3 channels
Page 354

Brake AB 20
24 VDC
0.1 Nm
Page 406